

INTRODUCTION

Thank you very much for purchasing Vapor Control Valve, VC-1000 Series. Please read through this instruction manual, for your proper operation.

1. OUTLINE

VC-1000 Series has the function as a flow rate controller and a vaporizer. It functions, together with a minor flow rate mass flow meter LF Series for liquid and a mass flow meter SEF-8000 Series for high temperature combined, to control the flow rate of the liquid and its vaporization at the same time to generate stable material. VC series has flat face construction and is very effective in vaporization, and has high resolution power controlling the opening of flat section by piezo-stack.

- FEATURES -

The control valve vaporizes liquid and controls its flow rate directly to suppress bubble generation in liquid feeding line. This is why the equipment can generate in succession stable vaporized gas.

The control valve is dead volume free and can respond at high speed.

The seat leakage through the valve (internal leakage) when the valve is fully closed is reduced to 1.0×10^{-5} atm · cc/s(He) { 1.0×10^{-6} Pa · m³/s(He)} or less.

By selecting either of the mass flow meter (LF Series) for liquid or the mass flow meter (SEF-8000 Series) for high-temperature gas, you can control flow rate either of the liquid or the vaporized gas. (Flow rate control)

Heater and temperature measuring sensor are built-in and an isothermal chamber is unnecessary.

VC series can be operated like an ordinary mass flow controller thanks to the combination with a mass flow meter.

Light weight and small size have realized easy installation in the gas panel system line.

2. SPECIFICATION *1

TYPE	VC-1310	VC-1410
Generating flow rate (Liquid Phase) *2	MAX. 0.5 CCM	MAX. 5.0 CCM
Liquid type	TEOS, H ₂ O, TiCl ₄ , C ₂ H ₅ OH etc. *3	
Heating temperature	MAX. 150	
Leak rate	External Leakage: 1.0×10^{-7} atm · cc/s(He) $\{1.0 \times 10^{-8}$ Pa · m ³ /s(He) } or less Internal Leakage: 1.0×10^{-5} atm · cc/s(He) $\{1.0 \times 10^{-6}$ Pa · m ³ /s(He) } or less	
Liquid/Gas-contact material	SUS-316L, (PTFE)	
Internal heater capacity	AC 120V 100W (50W × 2)	
Working temperature sensor	Thermocouple K type (CA)	
Fitting	Liquid Inlet 1/16" Special fitting 1/8 " VCR Male type 1/8 " Swagelok Gas Outlet 1/4 " VCR Male type 1/4 " VCR Female type	
Pressure resistance	10 kgf/cm ² G{1.1 MPa}	

* 1 As for your request for the material, refer to respective specifications.

* 2 The maximum flow rate varies in accordance with liquid type.

* 3 Please ask us about other liquid types not specified here.

3. DIMENSIONAL OUTLINE DRAWING

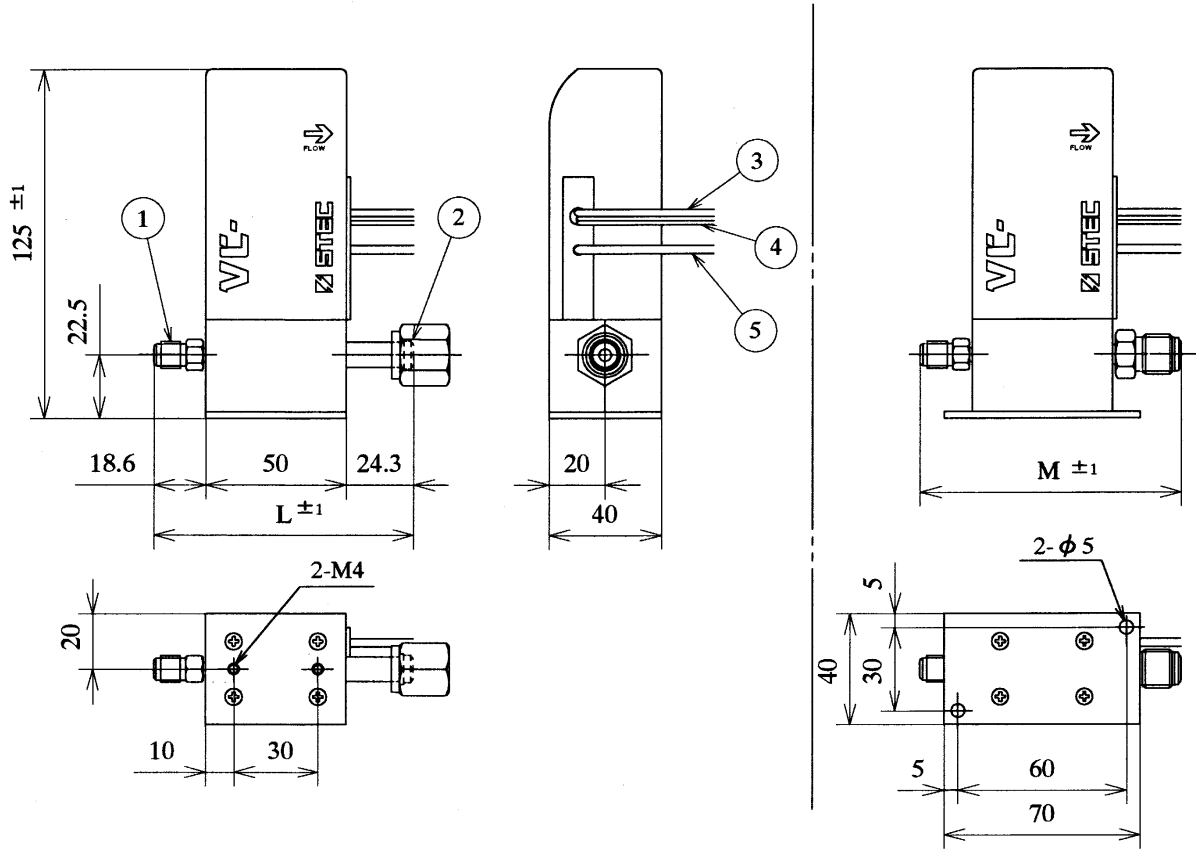

Parts No.	Component	Outlet fitting	L	M
1	INLET	Inlet fitting	1/4" VCR Female	1/4" VCR Male
2	OUTLET	1/16" Special fitting	90.3	90.6
3	Thermocouple	1/8" VCR Male	92.9	93.2
4	Heater	1/8" Swagelok	95.3	95.6
5	Cable for Piezo			

4. METHOD OF APPLICATION (LF + VC)

When controlling the vaporizing amount by means of the micro flowmeter for the liquid LF- 10A and the flow rate of the liquid, refer to the following method to connect and start up the equipment.

4-1. PIPING CONNECTION • ELECTRICAL CONNECTION (See the piping example)

- 1) Connect the piping matching the arrow on the machine body with the flow direction so as to place LF above VC. Keep a space by 50mm at least between LF and VC to prevent heat from transferring from VC to LF.

Decide the piping diameter taking its pressure loss in consideration for the purpose of controlling the pressure rise on the down-stream side while generating vapor.

In case liquid material contains particles, install a filter (abt. 0.01 μm) in the line.

VC is a normal open type. We recommend you to install pneumatic valve of normal closed type between LF and VC for an emergency stop due to power failure.

We recommend you to use 3-way double integrated valve for the introduction of purge liquid or purge gas.

After installed the piping line, clean it, before installing VC, with ethanol or the like.

- 2) Make a leakage test for respective fitting by means of helium leakage detector or the like.
- 3) Install a temperature measuring sensor such as a thermocouple to the down-stream piping of VC and wrap it with a tape heater and insulant.
(Refer to 13. PREPARING EXAMPLE FOR DOWN-STREAM HEATER PIPING)
- 4) Connect the cable lead from VC to the round connector at the top of LF.

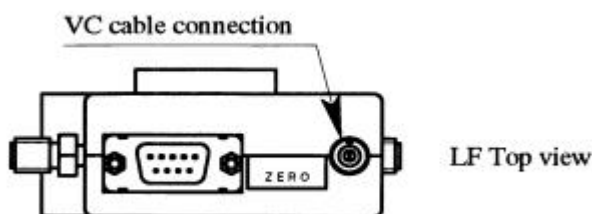

- 5) Refer to the instruction manual for LV Series to connect power source and signals.
Although LF Series is used, the electrical connection is similar to that for LV Series because of the setting signal required.
- 6) Connect the thermocouple and the heater of VC with the temperature controller. As the temperature controller for VC, use one with automatic tuning function of the P.I.D constant. Select proper temperature controller and SSR (Solid State Relay) for respective specifications (type of temperature sensor, capacity of heater) to connect the temperature sensor with the heater of VC's down-stream heater piping.

The thermocouple used for VC is K-type (CA) and the heater is of 100W (AC 120V).

Use a proper temperature controller and SSR for such specification.

For stable generation, use a temperature controller with short control cycle for VC (1 sec or shorter).

When using VC and a temperature controller unit for heater piping (HC-100 Series), connect only heater, thermocouple and power source.

4-2. START-UP • WARM-UP (See the piping example)

- 1) Turn on the power supply to the temperature controller to set the temperature for VC and the heater piping to the indicated temperature. (heating)

Preset temperature for VC varies according to the liquid type and the flow rate.

- 2) Warm the equipment for 30 minutes at least after the temperature starts rising. When stabilized the temperature, make automatic tuning for the control constant of the temperature controller.
- 3) After warming up, supply liquid material(s) as follows;

Vacuum the piping. (AV-2 and AV-5 is open)

When the liquid material reacts upon air (oxygen), we recommend a cycle purge where, after vacuuming, purge gas is introduced (V-2 is open) and then vacuuming again.

After turning on the power supply to LF, input the forced close signal. (Refer to the instruction manual for LV)

If input the voltage less than - 0.6 V as setting signal, the same operation as inputting forced close signal can be made.

The forced close signal is for closing the control valve of VC by force regardless of the liquid flow rate. By inputting this signal you can close VC's control valve even when the liquid material is not supplied at starting-up.

Set the primary pressure (material supplying pressure) at 1 to 2 kgf/cm²G. (V-1 is open)

Supply material to VC. (V-3 is open)

If not input the forced close in this case, too much liquid to be introduced might be supplied initially and the liquid is introduced without being vaporized into the down-stream side. So make sure the setting without fail before supplying.

The output signal of LF increases for a moment when supplying liquid material, but that is not a failure. It is to be reduced to 0 (zero) when filled the liquid up to VC.

(Make sure the signal.)

4-3. GENERATION

- 1) Input the setting signal and release the forced close signal in order to start generation.

The setting signal is 5V at its full scale flow rate. 0V is 0CCM.

$$\text{Setting Voltage (V)} = \frac{\text{Preset Flow Rate}}{\text{Full-scale Flow Rate}} \times 5.000 \text{ (V)}$$

After started generation, make sure of the normal generation by means of LF Output Signal.

Immediately after the start-up, there might be gas remained in the piping. Such residual gas might sometimes cause unstable generation. Release it through the exhaust line initially.

(AV-4 closed, AV-5 opened)

4-4. GENERATION STOP

- 1) Input the forced close signal in order to stop generation.

4-5. LONG-TERM STANDING • PURGE (Shutdown)

- 1) Input Forced Close to LF to stop generation.
- 2) Close the liquid supply line. (V-3 and AV-2 closed)
- 3) Open the liquid purge line to supply purge liquid. (AV-4 close, V-4, V-6, AV-3 and AV-5 opened)
- 4) Set the flow rate for LF at abt. 50 % F.S and then cancel Forced Close to vaporize the liquid material on the up-stream side in order to substitute it for purge liquid. After that, let the purge liquid flow and, meanwhile, purge the liquid in the piping.
- 5) Stop purge liquid supply and then supply purge gas to evaporate all the purge liquid.
(V-4 and V-6 closed, V-5 opened)
- 6) Stop the gas in the purge line and then vacuum the piping for about 10 minutes. (AV-3 closed)
- 7) Open the purge line to feed purge gas for about 1 minute. (AV-3 opened)
- 8) Repeat 6) and 7) above mentioned some times.
- 9) Stop the vacuuming and let the purge gas into the generation line. (AV-5 closed)
- 10) Stop the purge line and cool VC and heater piping to turn off the power supply to LF.

Close all the valves as well.

This is a typical purging method. The purging time depends on the length of the down-stream piping, secondary pressure or the like.

In case where the equipment is stopped completely for disassembling LF or the like, purge the liquid as well as gas in the material feeding line likewise in order to remove the liquid material in the piping at full.

The gas purge can be used for the liquid material with low reactivity and high vapor pressure. (H₂O, CH₃OH, C₂H₅OH etc.)

Select the liquid with low reactivity with the given material and high vapor pressure the liquid purge. (C₂H₅OH, THF etc.) When using mixed liquid in a solvent, use the solvent liquid as the purge liquid.

5. METHOD OF APPLICATION (VC + SEF)

Referring to the following method make connection and start-up of the equipment when controlling the vaporizing rate according to the evaporation flow rate combined with SEF-8000 Mass Flowmeter.

5-1. PIPING CONNECTION • ELECTRICAL CONNECTION (See piping example)

- 1) Connect the piping setting the arrow to the flow direction so as to place SEF behind VC.

If kept too much space between VC and SEF, the stability (response) against disturbance will deteriorate; do not place an excessive space. In case where VC's gas outlet fitting is of 1/4" VCR Female type, it is possible to connect directly with SEF and just insulant wrapping for the piping between VC and SEF will do. However, if place piping between VC and SEF, temperature control of the piping is indispensable.

For the purpose of controlling the temperature rise in the secondary pressure while generating vapor, take the loss of the pressure in the piping into consideration to fix the piping diameter.

If contained particle in the liquid material, install a filter (0.01 μm) in the line.

VC is a normal open type. So we recommend you to install an pneumatic valve of normal close type on the front stage of VC.

We recommend you to use 3-way double integrated valve for the introduction of purge liquid or purge gas.

After installed the piping line, clean it, before installing VC, with ethanol or the like.

- 2) Make a leakage test for respective fitting by means of helium leakage detector or the like.
- 3) Install a temperature measuring sensor such as a thermocouple to the down-stream piping of VC and wrap it with a tape heater and insulant. (Refer to 13.PREPARING EXAMPLE FOR DOWN-STREAM HEATER PIPEING)
- 4) Connect the cable led from VC to the round connector at the top of SMT-8000.

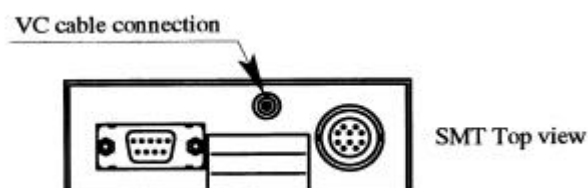

- 5) Refer to the instruction manual for SEF Series to connect power source and signals.
Although SEF Series is used, the electrical connection is similar to that for SEC-8000 Series because of the setting signal required.
- 6) Connect the thermocouple and the heater of VC and SEF with the temperature controller. As the temperature controller for VC, use one with automatic tuning function. Select proper temperature controller and SSR (Solid State Relay) for respective specifications (type of temperature sensor, capacity of heater) to connect the temperature sensor with the heater of VC's down-stream heater piping.

The thermocouple used for VC is K-type (CA) and the heater is of 100W (AC 120V).

Use a proper temperature controller and SSR for such specification.

The thermocouple used for SEF is K-type (CA) and the heater is of 100W (AC 120V).

(The capacity of a heater SEF-8340 is 56W (AC 100V))

Use a proper temperature controller and SSR for such specification.

For stable generation, use a temperature controller with short control cycle for VC (1 sec or shorter).

When using VC, SEF and a temperature controller unit for heater piping (HC-100 Series), connect only heater, thermocouple and power source.

5-2. START-UP • WARM-UP (See the piping example)

- 1) Turn on the power supply to the temperature controller to set the temperature for VC, SEF and the heater piping to the indicated temperature.(heating)

Preset temperature for VC and SEF varies according to the liquid type and the flow rate.

- 2) Warm the equipment for 30 minutes at least after the temperature starts rising. When stabilized the temperature, make automatic tuning for the control constant of the temperature controller.

- 3) After warming up, supply material(s) as follows;

Vacuum the piping. (AV-5 opened)

When the liquid material reacts upon air (oxygen), we recommend a cycle purge where, after vacuuming, purge gas is introduced (V-2 is open) and then vacuuming again.

After turning on the power supply to SEF, input the forced close signal.

(Refer to the instruction manual for SEF)

If input the voltage less than - 0.6 V as setting signal, the same operation as inputting forced close signal can be made.

The forced close signal is for closing the control valve of VC by force regardless of the liquid flow rate. By inputting this signal you can close VC's control valve even when the liquid material is not supplied at starting-up.

Set the primary pressure (material supplying pressure) at 1 to 2 kgf/cm²G. (V-1 is open)

Supply material to VC. (V-3 and AV-2 are open)

If not input the forced close in this case, too much liquid to be introduced might be supplied initially and the liquid is introduced without being vaporized into the down-stream side. So make sure the setting without fail before supplying.

5-3. GENERATION

- 1) Input the setting signal and release the forced close signal in order to start generation.

The setting signal is 5V at its full scale flow rate. 0V is 0CCM (SCCM).

$$\text{Setting Voltage (V)} = \frac{\text{Preset Flow Rate}}{\text{Full-scale Flow Rate}} \times 5.000 \text{ (V)}$$

After started generation, make sure of the normal generation by means of SEF Output Signal.

Immediately after the start-up, there might be gas remained in the piping. Such residual gas might sometimes cause unstable generation. Release it through the exhaust line.

(AV-4 closed, AV-5 opened)

5-4. GENERATION STOP

- 1) Input the forced close signal in order to stop generation.

5-5. LONG-TERM STANDING • PURGE (Shutdown)

- 1) Input Forced Close to SEF to stop generation.
- 2) Close the liquid supply line. (V-3 and AV-2 closed)
- 3) Open the liquid purge line to supply purge liquid such as ethanol.
(AV-4 close, V-4, V-6, AV-3 and AV-5 opened)

- 4) Set the flow rate for SEF at abt. 50% F.S and then cancel Forced Close to vaporize the liquid material on the up-stream side in order to substitute it for purge liquid. After that, let the purge liquid flow and, meanwhile, purge the liquid in the piping.
- 5) Stop purge liquid supply and then supply purge gas to evaporate all the purge liquid. (V-4 and V-6 closed, V-5 opened)
- 6) Stop the gas in the purge line and then vacuum the piping for about 10 minutes. (AV-3 closed)
- 7) Open the purge line to feed purge gas for about 1 minute. (AV-3 opened)
- 8) Repeat 6) and 7) above mentioned some times.
- 9) Stop the vacuuming and let the purge gas into the generation and supply lines. (AV-5 closed)
- 10) Stop the purge line and cool VC, SEF and heater piping to turn off the power supply to SEF. Close all the valves as well.

This is a typical purging method. The purging time depends on the length of the down-stream piping or the like.

The gas purge can be used for the liquid material with low reactivity and high vapor pressure. (H₂O, CH₃OH, C₂H₅OH etc.)

Select the liquid with low reactivity with the given material and high vapor pressure the liquid purge. (C₂H₅OH, THF etc.) When using mixed liquid in a solvent, use the solvent liquid as the purge liquid.

6. PIPING EXAMPLE

6-1. LF + VC

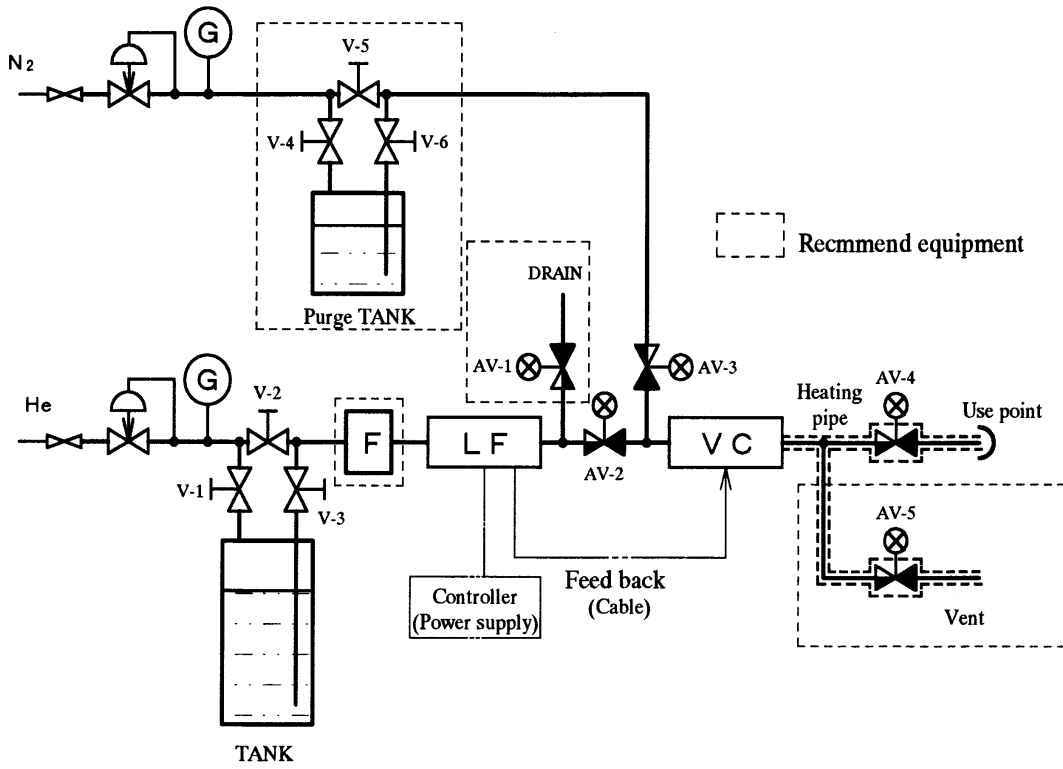

6-2. VC + SEF

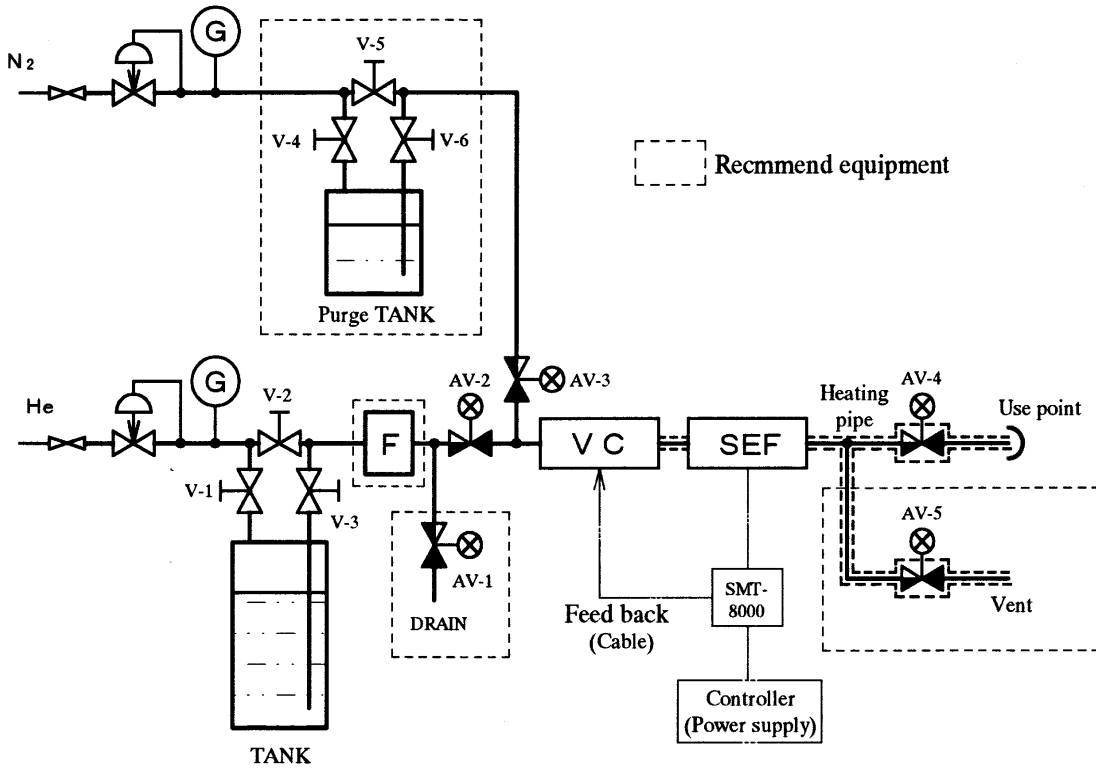

7. PERIPHERAL DEVICE

We are ready to supply special control unit and cable for our customers. Our specified devices will save you a lot of trouble in wiring and offer safety operation.

- LF + VC

Control Unit	PAC-D2 or the like
Cable	SC-LV
- VC + SEF

Control Unit	PAC-D2, PAC-S5 or the like
Cable	SC-DH2
- Temperature Control Unit

For VC	HC-100A
For SEF and Heater Piping	HC-100V

We have some other peripheral devices for you. Please refer to our catalogs.

8. VALVE OPENING/CLOSING INPUT (Forced Close/Forced Open)

For starting/stopping VC generation, the valves shall be opened/closed forcibly. Refer to the instruction manual for LF (SEF) for operation.

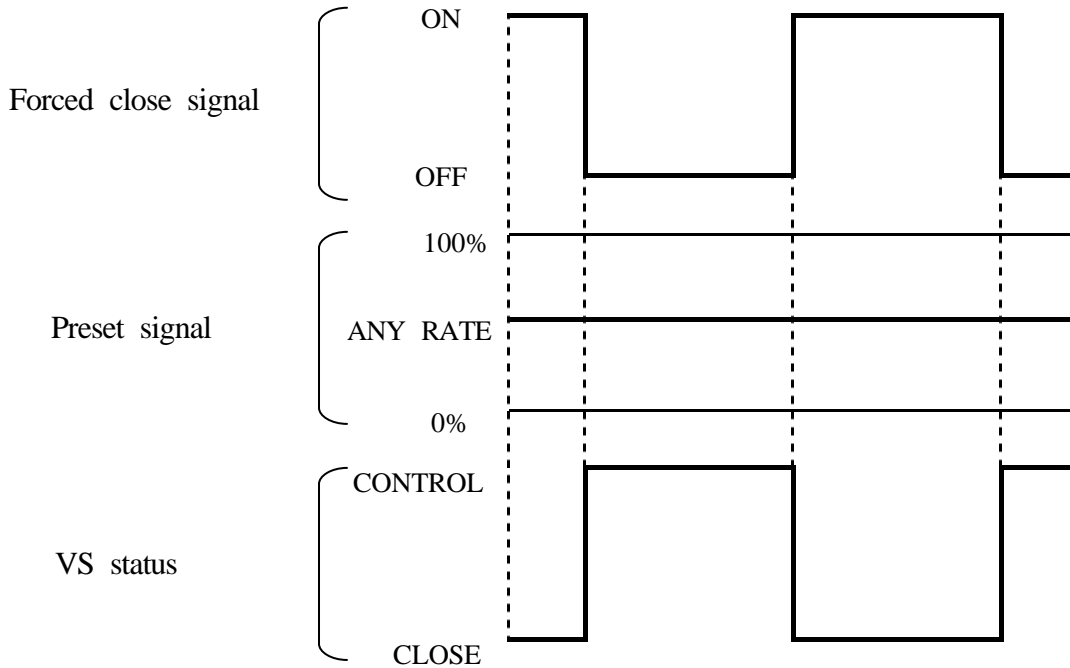

9. HOW TO DISASSEMBLE VC CABLE CONNECTOR

VC Cable connector is to be fixed with backstop at the tip of the connector. Therefore, after connected, the cable will not come off. Pull out the connector in the following manners.

- 1) Make sure the power supply to LF or to SEF is disconnected.
- 2) Slide the knurled part of the connector in the pulling out direction.
- 3) Keep the slid knurled part at the position, pull out the connector.

Caution

The cable connector may be broken without sliding the knurled part. Don't pull the connector by force.

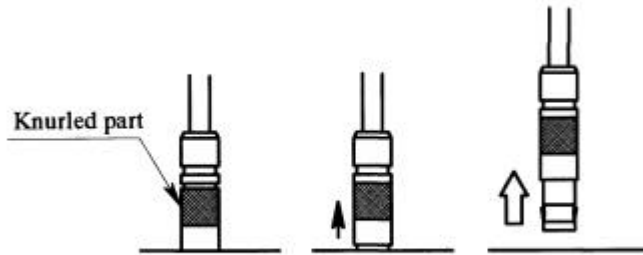

10. AUTO-ZERO (OPTION)

Auto-zero function can be added as an option to SEF-8000 Series. Refer to the instruction manual of SEF for the operation.

LF Series has no auto-zero function.

11. CARE FOR HANDLING

- 1) Make sure there is no leakage in the piping system and purge it at full.
- 2) Care shall be taken of the particles and impurity in the liquid material so as to keep VC valve drive normal.

When using a filter, we recommend a metal filter of 0.01 μm or a membrane filter of 0.05 μm .

- 3) The maximum working temperature is 150 . Avoid baking or usage at the temperature over 150 . VC contains a temperature switch of 145 . The switch is normally close type and connected with cartridge heater in series. If the internal temperature of VC rise at 180 and more, the switch is opened and turn off the heater. When the temperature of VC is cool down again, the temperature switch get close automatically.
- 4) VC Valve is driven by high voltage (abt. 120V). Never take off the main body case while supplying power.
- 5) When selecting the temperature controller for adjusting the temperature in VC, SEF and the heater piping, pay attention to the type of the sensor and the heater capacity.
- 6) VC is a normal open type. We recommend you to install an pneumatic valve of normal close type in the liquid phase line and air phase line (before chamber) for the power failure or emergency stop.
- 7) Warm VC and SEF completely before starting generation.
- 8) VC, SEF and the heater piping are to be heated and kept hot at high temperature. Therefore do not place them near the object to be affected or damaged by the heat.
- 9) VC, SEF and the heater piping are to be heated to high temperature. Never place them near flammables and combustible materials. **(CAUTION!)**
- 10) Never touch VC, SEF and the heater piping when heated. You might get burned. **(CAUTION!)**
- 11) Refer to the instruction manual for LF and SEF for others.

12. TROUBLESHOOTING

Checkout the following points when there is some trouble in the flow rate control and temperature conditions of VC.

- VC Temperature is not stable

CAUSE	COUNTERMEASURE
PID Constant is not proper for Temperature Controller.	Make automatic tuning of Temperature Controller at the working condition (supply voltage,temperature etc.)
Leakage of Heater Supply Power	Turn off the power supply once and check Heater Power Line for leakage.
Voltage supplied to Heater is too low	Supply voltage to Heater up to AC 120V.
Improper contact of Thermocouple	Make sure the connection of Thermocouple to Temperature Controller.
Controlling Cycle of Temperature Controller is too long.	Use a temperature controller with cycle of 1 sec or less. In case of cycle adjustable one,set it to 1 sec or less.

- VC and SEF will not be heated

CAUSE	COUNTERMEASURE
Power is not supplied to Heater	Check connection with Heater and then supply power to Heater
Signal from Temperature Controller is not input to SSR or Power Controller	Install proper connection
Leakage in Power Supply to Heater	Turn off the power and check Heater Power Line.
Temperature Controller is not set for anything	Input the setting as specified to Temperature Controller

- VC Temperature is not stable. Not to be reset. (While generating)

CAUSE	COUNTERMEASURE
Material is fed over the limit to flow rate	Generation shall be started with forced close condition of VC (See P.10)
Flow rate is not stable	Refer to the case with instable flow rate indication
No vaporization in VC or re-condensing	Check out secondary pressure, temperature and warm-up time

- Instable Flow Rage Indication. Below the Full-scale

CAUSE	COUNTERMEASURE
Primary pressure (Supply Pressure)is low (high)	Set the primary pressure to the sepcified one
Secondary pressure is high and re-condensing VC is not heated to the preset temperature	Set the secondary pressure to the sepcified one Check the preset temperature for VC and that indicated by Temperature Controller
There is some bubbles in the liquid material	Check upstream piping for leakage Remove the bubbles retained in upstream piping
Failure in Flow meter	Stop material feeding and make sure the zero point of Flow meter and stability. (If found any trouble, contact us.)
Seat leakage in VC	Input forced close to VC and check it for seat leakage. (See the case of seat leakage)
Cable from VC is not connected with LF (or SMT-8000)	Connect the cable

- There is seat leakage (at forced close)

CAUSE	COUNTERMEASURE
Primary pressure (Supply Pressure)is too high	Reduce Primary pressure to the specified one.
Forced Close Signal is not input.Preset signal is not negative	Check connection and signal
VC temperature is too high	Cool VC down to the specified temperature
Cable from VC is not connected with LF (SMT-8000)	Connect the cable

If not troubleshootered with this, please contact us.

13. PREPARING EXAMPLE FOR DOWN-STREAM HEATER PIPING

Use temperature measuring sensor, tape heater and insulant to heat and keep down-stream Piping and pneumatic Valve hot. Take much care of the sensor position and tape heater wrapping so as to make even heating as possible.

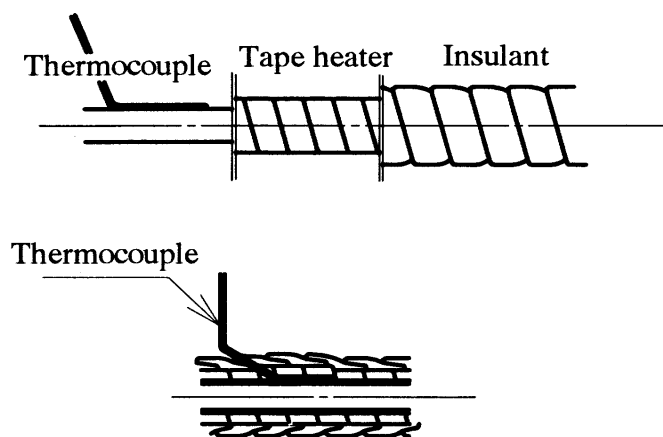

14. CONNECTING EXAMPLE FOR TEMPERATURE CONTROLLER

When using Temperature Controller and SSR to control temperature for VC and SEF, refer to the drawing here to install connection.

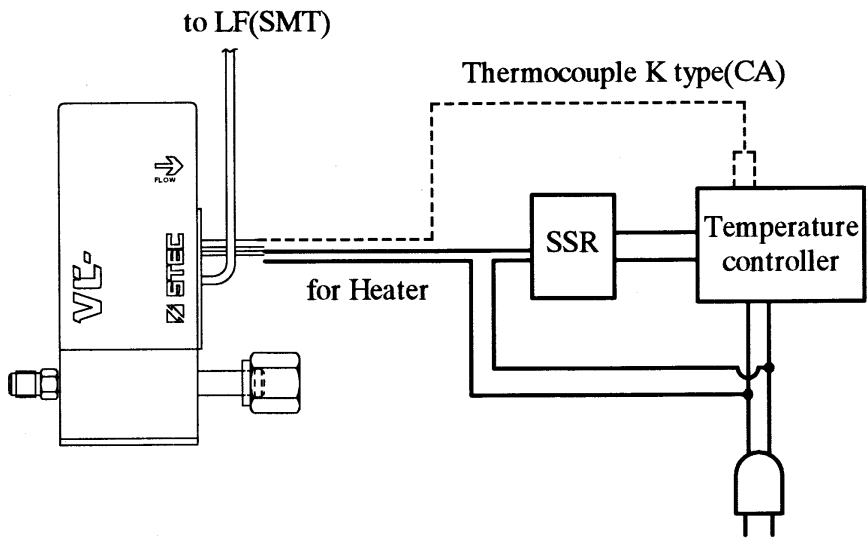

15. PRODUCT WARRANTY

15-1. PERIOD

One year after purchasing the machine. As for the trouble or failure caused and informed to us during this period, we will repair for nothing.

15-2. SCOPE

The scope of the guarantee is limited to the present machine. Compensation for loss due to the failure of the present machine is out of scope.

15-3. RENEWAL PARTS

Either of 90 days after the previous renewal or the term provided in 15-1, which is longer.

15-4. HOLD HARMLESS CLAUSE

The following cases, even during the term of guarantee, will be out of the scope.

- 1) Failure due to force majeure such as a natural disaster.
- 2) Failure due to customer's mistreating or negligence to the care for operation.
- 3) In case where used or stored under improper conditions.
- 4) In case where operated out of the rated specifications.
- 5) In case where the machine is revamped or used for other purpose than specified.
- 6) Other cases to be considered out of our responsibility.